

- Meimberg, H., Dittrich, P., Bringmann, G., Schlauer, J., Heubl, G. 2000, Molecular Phylogeny of Caryophyllidae s.l. Based on matK Sequences with Special Emphasis on Carnivorous Taxa. *Plant Biol.* 2: 218-228.
- Schlauer, J. 1997, "New" Facts Relating to the Phylogeny of Some Carnivorous Plant Families. *Carniv. Pl. Newslett.* 26: 31-33.
- Schulze, W., Schulze, E.D., Pate, J.S., Gillison, A.N. 1997, The Nitrogen Supply from Soils and Insects During Growth of the Pitcher Plants *Nepenthes mirabilis*, *Cephalotus follicularis* and *Darlingtonia californica*. *Oecologia* 112: 464-471.

## Writings from the Readership

---

# REFINING THE TERRARIUM: ALTERNATIVE TECHNIQUES FOR THE INDOOR GARDENER

MIKE WILDER • 301 SE 53rd Avenue • Portland, OR 97215 • USA •  
it\_290@hotmail.com

Keywords: cultivation: *Nepenthes*, terrarium.  
Received: 10 April 2000

The quantity of literature pertaining to the indoor cultivation of *Nepenthes* is far from overwhelming. The two essays I have found most useful appeared in the pages of this journal: "A Rainforest In The Basement: *Nepenthes* Cultivation Under Lights" (Butler, 1987), and "The Potted Terrarium" (D'Amato, 1996). Butler's piece described the construction of a basement grow-chamber for his "intermediate" *Nepenthes*. D'Amato's article, which is more important for our purposes, described two styles of terraria which were well-suited for a general carnivorous plant collection. Both of the foregoing works were instrumental in my early attempts to grow carnivorous plants, and especially *Nepenthes*, indoors. Nonetheless, neither article provides an optimal method for growing lowland *Nepenthes* indoors. In this article I will describe and advocate two modifications to D'Amato's "potted greenhouse style terrarium" (henceforth "potted terrarium"). These modifications yield improved growing conditions for lowland *Nepenthes* without any sacrifice in convenience. Furthermore, the "refined" potted terrarium has a few other useful applications. Before getting on to this, I will review D'Amato's article.

At the time of publication D'Amato's article was perhaps the most important discussion of carnivorous plant culture in terraria. I remember thanking him personally at a Bay Area Carnivorous Plant Society meeting for sharing such useful information. (The piece reappeared in his book, much supplemented.) In contrast with the paradigmatic terrarium containing a planted soil bed, D'Amato advocated simply placing potted plants directly on the terrarium floor. As he pointed out, this simple change allowed one to grow plants requiring a variety of different soils and soil moisture levels in the same terrarium. This versatility, I think, is the chief benefit of the potted terrarium; it constitutes a dramatic improvement over the planted tank.

While acknowledging the great utility of the potted terrarium, it proves deficient for the lowland *Nepenthes* grower in two areas. The first is watering. Unlike many carnivorous plants, *Nepenthes* will not tolerate standing in water. Hence, one must remove the plants, water them, let them drain, and then return them to the terrarium. This is incredibly inconvenient. The alternative D'Amato suggested is to sit each potted *Nepenthes* in "a shallow saucer and water overhead as soon as the water in the saucer evaporates" (D'Amato, 1998, p 277). Though he cautioned the

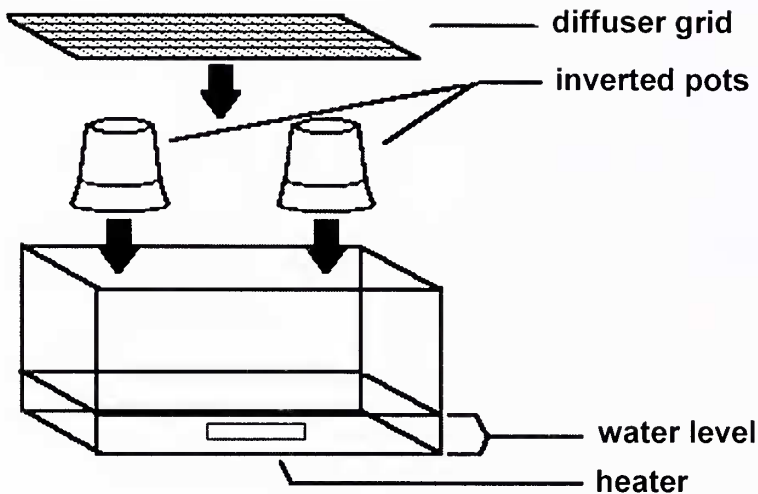

Figure 1: Setting up the refined terrarium.

reader not to let plants sit in deep water for extended periods, I find this method of watering unacceptably risky. Furthermore, Barry Meyers-Rice reports that he has had unsatisfactory results letting *Nepenthes* sit in water (personal communication, 1999).

The second area of difficulty is heating. Though some lowlanders will tolerate consistent temperatures around 18°C (approximately 65°F), most will not. Indeed, my clone of *N. ventricosa*, a highland species, completely ceased growth one winter when the room temperature never rose above 18°C (65°F). Even if the plants tolerate these lower temperatures, growth is very slow. A heater would help. Although many manufacturers produce electric heating mats, the mats tend to have a surface area far smaller than most terraria. Furthermore, most are designed to heat a seed-flat, not the large air/soil volume of a 120-200 liter (30-50 gallon) terrarium. Hence, these mats are of minimal utility (especially considering their cost). Again, D'Amato proposed an alternative. He suggested that one submerge an aquarium heater in a jar of water placed in the terrarium. Though aquarium heaters are cheaper than the aforementioned mats, they have their own shortcomings. The small volume of water in the jar evaporates rapidly, and while this does help increase humidity, the water must be continually topped-off. (Submersible aquarium heaters exposed to air may crack, creating a potentially hazardous situation.) Furthermore, these heaters do not produce enough heat to do the job.

In the next section, I will describe how to set up a “refined” potted terrarium, which incorporates my two modifications to the standard potted terrarium.

In addition to an empty aquarium, you will require a submersible aquarium heater and a sheet of plastic lighting diffuser grid. In essence, the bottom of the aquarium is used as a heated water reservoir, and the plastic grid acts as a raised platform or staging for the plants (see Figure 1). Submersible aquarium heaters are available in several power ranges, from 50 to 300 watts. Generally, the wattage desired is determined by the volume of water to be heated; 1.25 watts per liter (5 watts per gallon) is the aquarist’s rule of thumb. Assuming that one begins with a 220 liter (55 gallon) aquarium, a 7.5 cm (3 inch) deep water reservoir would be roughly 40 liters (10 gallons). The rule of thumb dictates that a 50 watt heater should be sufficient for a tank this size or smaller. However, it is important to remember that this heuristic was designed for the fishkeeper, not the *Nepenthes*



Figure 2: A 160 liter (40 gallon) terrarium containing *Nepenthes* and *Cephalotus*.



Figure 3: Young plants of *D. derbyensis* growing in heated water.

grower. Although we want to heat the water, our true object is to heat the much larger volume of air and soil in the tank. Hence, I recommend doubling the figure to 2.5 watts per liter (10 watts per gallon) of water. Following this new rule, I therefore use a 100 watt heater for tanks with volumes of 120-220 liters (30-55 gallons), and a 50 watt heater for smaller tanks. The heater is placed horizontally on the floor of the aquarium. Its thermostat should be set to 30°C (85°F) or its highest temperature setting, whichever is lower. The tank should then be filled with 7.5 cm (3 inches) of water, ensuring that the heater is completely submerged. Those who grow only highland plants may wish to consider putting the heater on the same timer as the lights, so that temperatures rise and fall each day. With my collection, however, I have found this unnecessary.

In the USA, lighting diffuser grid is available in 60 × 120 cm (2 × 4 foot) sheets, and is made of an inert plastic. In the USA, it sells at large hardware stores for about \$6 per sheet. Cut it to fit your terrarium floor. The grid will become the platform for your plants. Use overturned flower pots as stilts to elevate the grid off the terrarium floor. Make sure the grid will be above the water level in the terrarium, and will also provide plenty of room for your pots and the growing room your plants will require. The grid is rigid but not especially strong, so make certain that it is well supported at the center and edges. Once the flower pot supports, grid platform, and water are all in place, turn on the heater and arrange the *Nepenthes*.

The refined potted terrarium has many benefits. The ambient room temperature where I have my *Nepenthes* terraria (in a basement) is a constant 15-18°C (60-65°F), and the humidity is well below 50%. I grow my seedlings, unrooted cuttings and smaller rosetted plants in a 120 liter (30 gallon) terrarium. The platform is 18 cm (7 inches) above the aquarium floor. My larger plants grow in a 160 liter (40 gallon) tank, and its platform is only 10 cm (4 inches) above the floor (Figure 2). The plants can be watered in place; they drain freely, and the runoff keeps the reservoirs full. The plants sit 5-15 cm (2-6 inches) away from the light fixture. I have found that two fluorescent bulbs (the same length as the terraria) provide ample light when plants are this close. The air temperature inside both sealed terraria remains a satisfying 27°C (80°F), and the humidity stays constant at 90%. Given that I am using measly 100 watt heaters, this is a substantial temperature increase at a very low cost. Furthermore, air convection currents circulate warm moist air around the plants.

I have used this method quite successfully over the last few years with many plants, including *N. rafflesiana*, *N. truncata*, *N. gracilis*, *N. × hookeriana*, *N. ventricosa*, *N. × wrigleyana*, *N. × ventrata*, *N. × ventrata* × species, *N. veitchii* × *lowii*, and other unlabeled hybrids. (The inclusion of highland *Nepenthes* on this list may raise some eyebrows, but they grow well in these conditions!) *Cephalotus follicularis* has also grown quite vigorously in this environment; the 2 cm (3/4 inch) cutting I started with now requires a 15 cm (6 inch) diameter pot! My *N. truncata* provides the most dramatic demonstration of the refined terrarium's utility. When I obtained it, it was a sorry specimen with small, sickly leaves and dinky, poorly colored 3.75 cm (1.5 inch) pitchers. Just six months later, the plant began producing substantial 18 cm (7 inch) pitchers with rich coloration.

The refined terrarium can be modified for special applications. I particularly enjoy growing carnivorous plants from seed. After experimenting with several methods to heat seedlings, I achieved the best results by slightly modifying the method presented above. Instead of raising the platform above the water reservoir, I raise the water level to 2.5 cm (1 inch) above the platform. The plants sit in 25-27°C (78-80°F) water. Germination and growth of tropical *Drosera* and *Pinguicula* is quite rapid in such conditions. Also, the heat significantly reduces the occurrence of fungal attacks on newborns, and those that do occur are less severe. Many growers today are extremely interested in *Drosera* that are in section *Lasiocephala* (i.e.

related to *D. petiolaris*). I have found that these potent Aussies (e.g. *D. ordensis*, *D. derbyensis*, and *D. paradoxa*) really perk up when grown in heated water (Figure 3).

The method of terrarium culture presented here has provided excellent growing conditions for several genera of carnivorous plants. I sincerely hope that other growers will find this method useful, especially those who are not blessed with a greenhouse. Apartment dwellers, students, and others who crave choice rainforest plants can enjoy a lush indoor garden. Even greenhouse owners may find this method ideal for pampering a newly imported *N. clipeata*, or for experimenting with the exciting perennial tropical *Drosera*.

#### Literature

Butler, D. 1987, A Rainforest in The Basement: *Nepenthes* Cultivation Under Lights, Carniv. Pl. Newslett., 16, 83-87.

D'Amato, P. 1996, The Potted Terrarium, Carniv. Pl. Newslett., 25, 103-105.

D'Amato, P. 1998, The Savage Garden, Ten Speed Press, Berkeley, p. 41-47.

---

## NEWS AND VIEWS

Kenneth Skau (3176 Sunny Hollow Lane, Cincinnati OH 45239, ken.skau@uc.edu) wrote: The Krohn Conservatory in Cincinnati, Ohio, USA sponsored a "Join a Plant Society Weekend" February 26-27, and I made a display so the ICPS was represented. Barry Meyers-Rice (who was the person contacted by Krohn) provided some back issues of Carnivorous Plant Newsletter and membership application forms. Meanwhile, I made up a poster with some information about the society (shamelessly plagiarized from the web site) and some pictures of carnivorous plants. Unfortunately, I was out of town over that weekend and did not feel comfortable providing any of my plants for the event. There were over 3,000 visitors, which has encouraged the conservatory to make this a yearly event. The conservatory will be sponsoring a "Bug Fest" in the fall in which I hope to participate and display some live bug eaters.

David Parker (13516 Parker Ave., Grandview, MO 64030 USA, david.a.parker@mail.sprint.com) writes: I have been growing Venus flytraps and other carnivorous plants for the past eight years. The pride of my collection are twelve Venus flytraps that are over twenty years old. These plants produce very large traps. This summer I measured traps that were just over 5 cm (2 inches) long. I remove the flower stalks as soon as they appear in spring, and feed the plants constantly during the growing season. I feel these factors and the plants' ages are responsible for their large size. These plants continue to get bigger every year and it would not surprise me if they produce 6 cm (2 1/4 inches) traps next summer. I feed them wax worms that I get at the local bait or pet care stores. I find it is easier to handle them than crickets or other insects. They also seem to be very easy for the plants to digest—they do not rot and kill the trap leaves as long as one worm is fed to a trap. Just before I feed wax worms to the plants I place them in the refrigerator for 10-15 minutes. This keeps them immobile. After I place them in the traps, and the traps close, the wax worms warm and slowly start to move again. This triggers the traps into their digestive phase. The wax worms are not that strong and rarely escape or damage the trap.

Barry Meyers-Rice (P.O. Box 72741, Davis, CA 95617 USA) writes: The US postal service has announced that in 2001 it will publish four carnivorous plant stamps. *Dionaea muscipula*, *Sarracenia flava*, *Darlingtonia californica*, and *Drosera anglica* will be featured on the new 34 cent stamps.